



TECHNICAL DATA  
FROM  
**Anemostat**<sup>®</sup>  
DOOR PRODUCTS  
A MESTEK COMPANY

P.O. BOX 4938 • 1220 WATSONCENTER ROAD  
CARSON, CA 90745-4206  
(310) 835-7500 • FAX (310) 835-0448

e-mail: door@anemostat.com • website: www.anemostat.com

**SSD**

SECURITY SLIDING DOOR  
FOR SELECTIVE VISION  
INTO HIGH SECURITY AREAS



FIRE  
RATINGS



UNDERWRITERS'  
LABORATORIES

WARNOCK  
HERSEY

**B.S.-476.22** British Standard

**DETAIL DRAWING**

**NOTE:** Door slides from side to side. Non-centered vision frame cutout is generally required, i.e. 12" x 12" LoPro vision frame requires 26" x 13" SSD with vision frame set to one side of door, not centered.

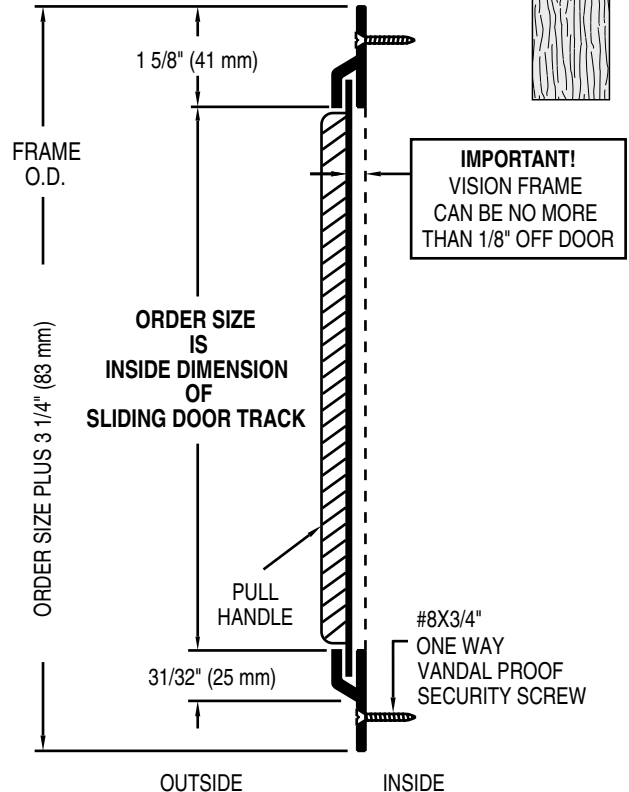
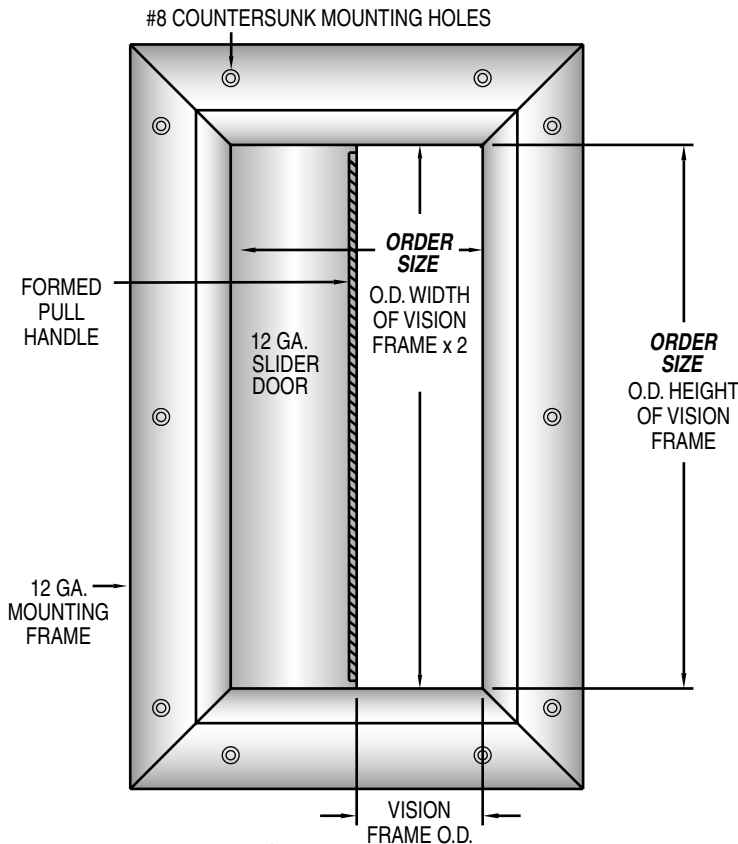

Anemostat manufacturing dimensions ±1/32  
Actual dimensions are nominal and may vary based on component manufacturers tolerances.

**NOTE:** When used with vision frame other than LoPro, or SG-10 outside dimensions of frame must be furnished.

**STANDARD PRODUCT FEATURES**

- MATERIAL:** 12 GA. Cold Rolled Steel Channel Frame and Sliding Door.
- FINISH:** Grey Primer, Beige or Bronze Baked Enamel.
- INSTALLATION:** #8X3/4" one way vandal proof security screws.
- DOOR THICKNESS:** Works on Doors 3/4" and greater.
- USES:** To provide selective vision into security areas. Use with Anemostat SG-10 security vision frame or LoPro™ (see tech. data sheet) or retrofit with existing vision lite kit (refer to dimensional data).
- NOTE:** For Exterior use, High Humidity or Salt Air application, product must be Galvanized or Stainless Steel.
- IMPORTANT:** Interpretation of building and fire codes may vary. Consult with the local authority having jurisdiction in your area, to determine appropriate standards.

**OPTIONAL FEATURES**

- MATERIAL:** #304 or #316 Stainless Steel, #4 Finish (Satin), Galvanized (Zinc Plated).
- FINISH:** Custom Baked Enamel Colors (as per sample chip supplied).
- FASTENERS:** Special Security Screw Fasteners, See page 27, this section.
- SPECIALS:** Fractional sizes and other steel gauges (contact factory).

**FIRE RATINGS (w/ U.L. & W.H.I. classification markings) Positive Pressure**

- 20/45 MINUTE:** Approved listing at 1296 sq.in. visible lite (max. width 36", max. height 36").
- 60/90 MINUTE:** Approved listing at 100 sq.in. visible lite (max. width 10", max. height 33").

**BS 476.22** British Standard  
Timber Doors - 30 min. and 1 hour.  
Steel Doors - 2 hours (4 hours actual).

Job Name & Location	Submitted by