



TECHNICAL DATA
FROM
Anemostat[®]
DOOR PRODUCTS
A MESTEK COMPANY

P.O. BOX 4938 • 1220 WATSONCENTER ROAD
CARSON, CA 90745-4206
(310) 835-7500 • FAX (310) 835-0448

e-mail: door@anemostat.com • website: www.anemostat.com

SL-IS

METAL VISION FRAME
WITH SECURITY GRILLE FOR
STANDARD/SPECIAL DOOR OR
GLASS THICKNESS



UNDERWRITERS'
LABORATORIES

FIRE
RATINGS



WARNOCK
HERSEY

DETAIL DRAWING

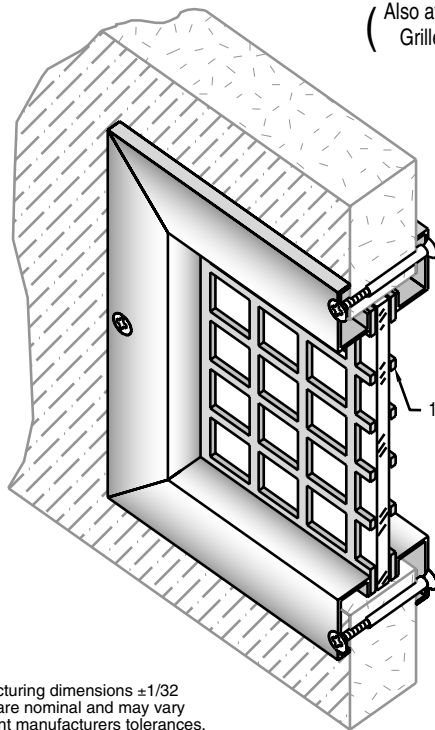

(Also available with Security Grille on one side only)

12 GA. SECURITY GRILLE

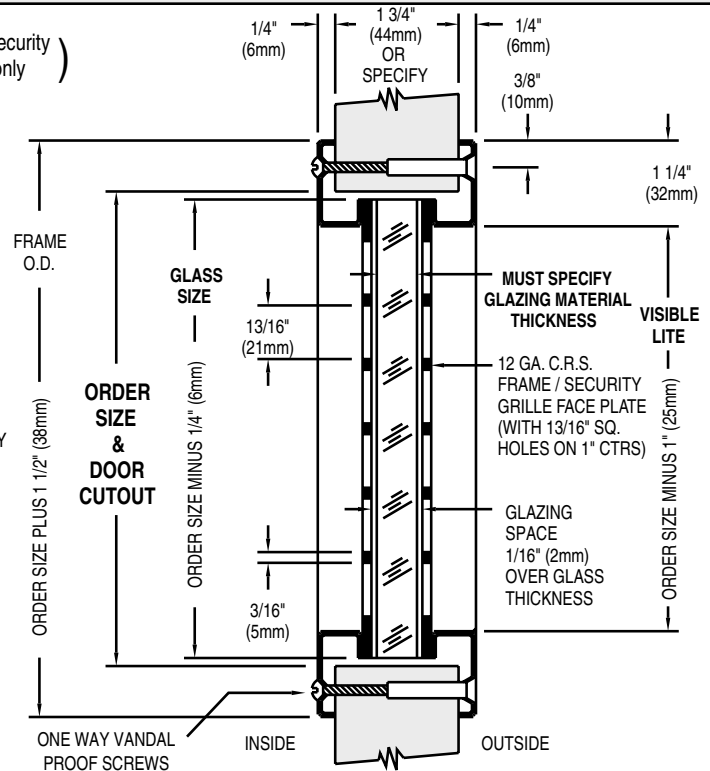

Anemostat manufacturing dimensions ±1/32
Actual dimensions are nominal and may vary
based on component manufacturers tolerances.

STANDARD PRODUCT FEATURES

- **MATERIAL:** 18 GA. Cold Rolled Steel Frame, with 12 GA. Cold Rolled Steel Security Grille (13/16" square Holes on 1" centers).
- **FINISH:** Grey Primer, Beige or Bronze Baked Enamel.
- **INSTALLATION:** By drilling 1/4" holes thru the door, around the perimeter of the door cutout. Frame has countersunk mounting holes for #8x32 one way vandal proof security screw thru bolts with a blank head on one side for flush appearance.
- **DOOR THICKNESS:** 1 3/4" (std), or up to 2 1/4" (specify).
- **GLAZING:** Thickness can range from over 3/16" and up to 1 9/16". Glazing space of 1/16" over glass thickness is standard, allowing for glazing tape to be used on both sides of the glass.
- **USES:** For use where visible lite is required, but security on one or both sides of the glass is necessary.
- **NOTE:** For Exterior use, High Humidity or Salt Air application, product must be Galvanized or Stainless Steel.

OPTIONAL FEATURES

- **MATERIAL:** #304 or #316 Stainless Steel, #4 Finish (Satin), Galvanized Hot Dipped or Zinc Plated). Not available in Galvanized Sheet.
- **FINISH:** Custom Baked Enamel Colors (as per sample chip supplied). Plated Finishes to match the lock, hinges and closer.
- **FASTENERS:** Special Security Screw Fasteners, See Page 26, this section.
- **SPECIALS:** Fractional Sizes, Lead Lined for X-ray applications. Special Glass or Door Thickness.

FIRE RATINGS (w/ U.L. & W.H.I. classification markings) Positive Pressure

- **20/45/60* MINUTE:** Approved listing at 1296 sq. in. visible lite. (max. width 54", max. height 54").
 - **60**/90** MINUTE:** Approved listing at 1080 sq. in. visible lite. (max. width 35", max. height 35").
 - **60/90 MINUTE:** Approved listing at 100 sq. in. visible lite. (max. width 10", max. height 33").
- *Must be used with FIRELITE Plus or NT and Fire listed glazing tape or another manufacturer's equivalent product. Glazing combination must be used in appropriately tested door assembly.
 **Must be used with 7/8" (23mm) or 1-1/16" (27mm) Pyrostop and fire listed glazing tape, and be used in an appropriately tested door assembly.
- **IMPORTANT:** Interpretation of building and fire codes may vary. Consult with the local authority having jurisdiction in your area, to determine appropriate standards.

Job Name & Location	Submitted by