



TECHNICAL DATA

FROM

Anemostat[®]

DOOR PRODUCTS

A MESTEK COMPANY

1220 E WATSON CENTER RD
 CARSON, CA 90745-4206
 (310) 835-7500 • FAX (310) 835-0448

e-mail: door@anemostat.com • website: www.anemostat.com

LoPro™-BB1-MB

LO-PROFILE
 METAL VISION FRAME
 WITH
 INTERNAL MINI-BLIND
 GLASS UNIT

NOT FIRE RATED

CATEGORY II IMPACT/SAFETY RATED

MINI-BLIND UNIT
 PATENT # 5,699,845

DETAIL DRAWING

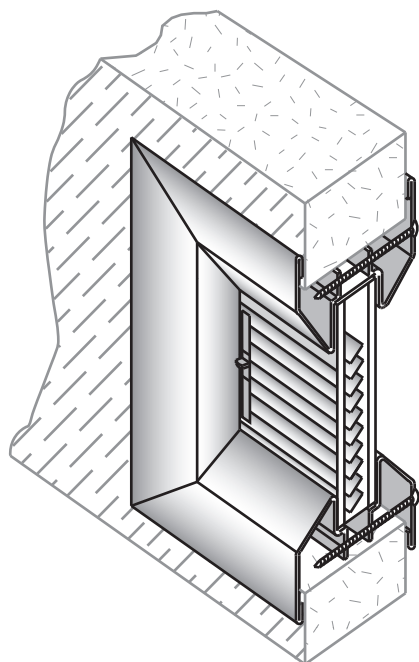

(Only Available in LoPro™-BB1 with
 1" insulated glass/mini blind unit.)

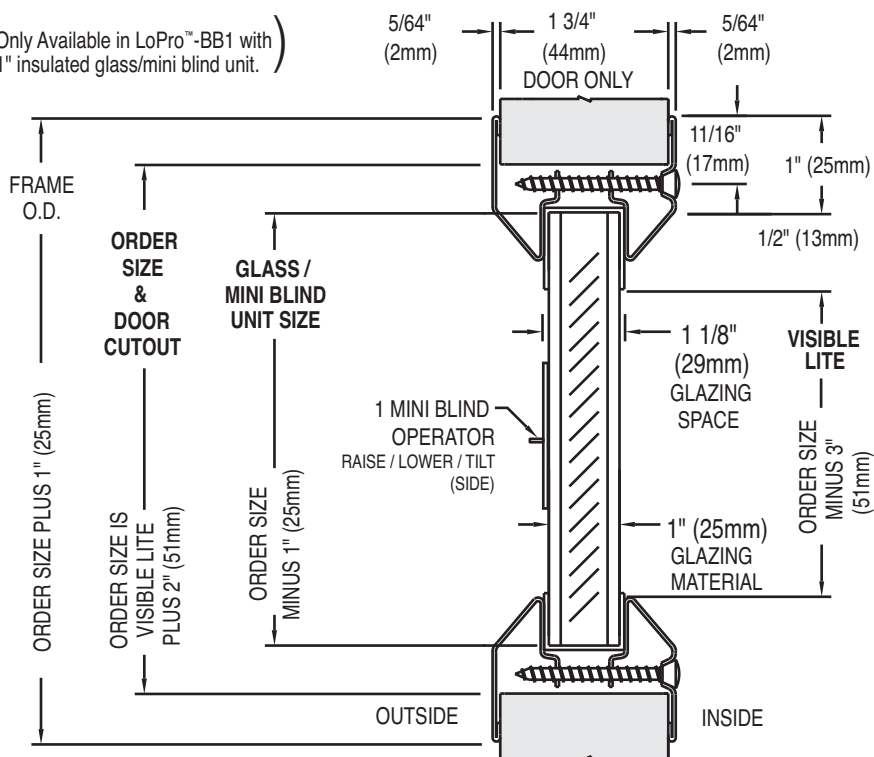

Anemostat manufacturing dimensions ±1/32
 Actual dimensions are nominal and may vary
 based on component manufacturers tolerances.

STANDARD PRODUCT FEATURES

- MATERIAL:** 20 GA. (1mm) Cold Rolled Steel Vision Frame.
- MINI-BLIND:** Available in white only. Internal Mini-Blind with nylon cord, adjustable painted aluminum blades, sealed in clear tempered glass, 1" overall thickness. Blind will raise, lower and tilt. Adds privacy and security.
- SIZES AVAILABLE:**

9"x37"	9"x65"	21"x37"	23"x37"
(Door Cutout Size)	(229 x 940mm)	(229 x 1651mm)	(533 x 940mm)
		(533 x 1651mm)	(584 x 940mm)
8"x65"	15"x65"	21"x65"	23"x49"
(203 x 1651mm)	(381 x 1651mm)	(533 x 1651mm)	(584 x 1245mm)
			(584 x 1651mm)
			(tilt only)

Custom sizes not available.
- FINISH:** Vision Frame: Grey Primer, Beige or Bronze Enamel.
- INSTALLATION:** This product is easy to install and provides a low profile, flush to the door look. Uses 1 3/4" (44mm) sheet metal screws that pass through the door cutout, and fastens to the opposite side of the vision frame, saving installation time and labor. It also leaves the corridor side of the frame free of fasteners for added security and a cleaner, more aesthetic appearance.
- DOOR THICKNESS:** For 1 3/4" (44mm) Wood or Metal doors.
- AESTHETICS:** Tight mitered corners, beveled glass stop and low profile, provide a clean tapered look.
- USES:** Hospitals, Judicial and Police Facilities, Board Rooms, Offices or anywhere flexible privacy is required.

OPTIONAL FEATURES

- MATERIAL:** #304 or #316 Stainless Steel, #4 Finish(Satin), Galvanized (Coil, Hot Dipped, or Zinc Plated).
- FINISH:** Custom Baked Enamel Colors (as per sample chip supplied). Plated Finishes to match the lock, hinges and closer.
- FASTENERS:** Special Security Screw Fasteners available, see page 36 this section.

FIRE RATINGS

- LoPro™-BB1-MB is not fire rated.

IMPACT / SAFETY RATINGS

- Meets ANSI Z97.1 and CPSC 16CFR1201 (Cat. I and II)

CONFORMS TO THE FOLLOWING

- ASTM C 1036
- ASTM C 1048
- NOTE:** For Exterior use, High Humidity or Salt Air application, product must be Galvanized or Stainless Steel.

Job Name & Location	Submitted by