

MACHINING DETAILS

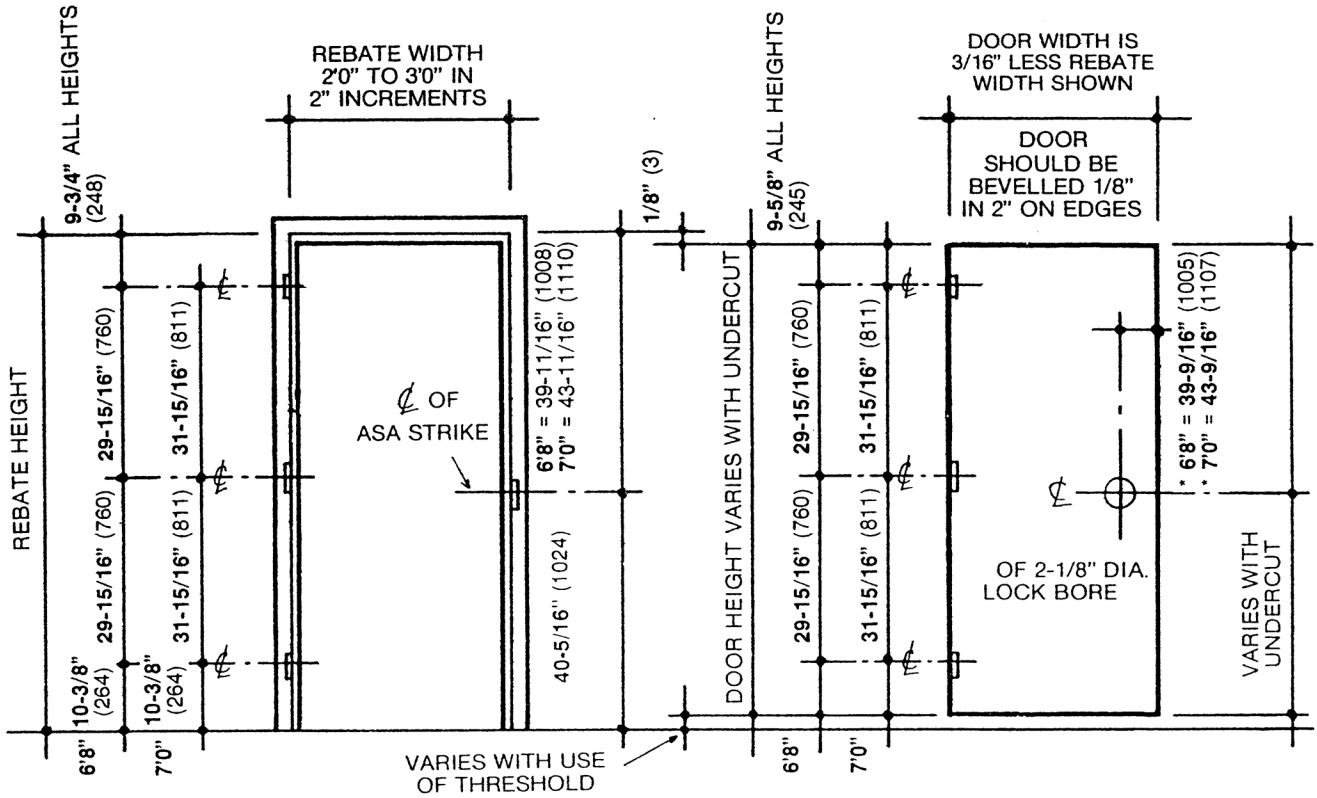

\* THIS DIMENSION VARIES WITH THE USE OF DIFFERENT TYPES OF LOCKS

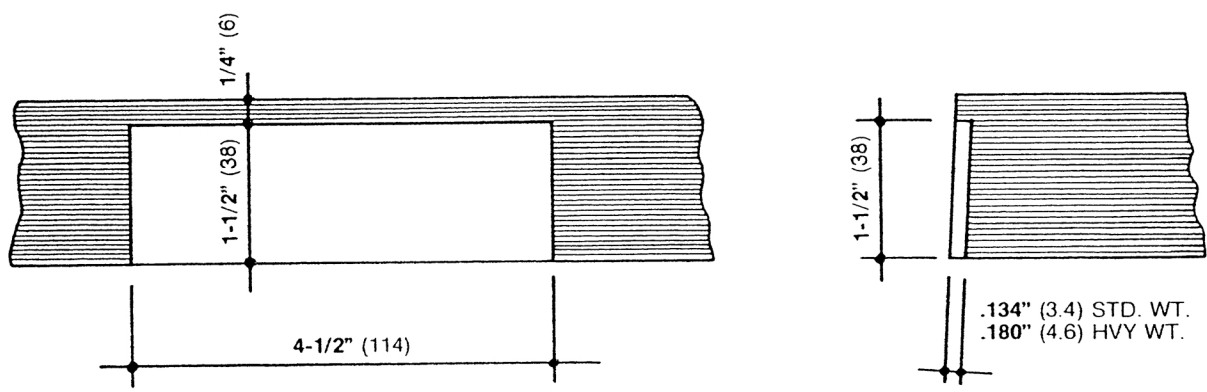

DOOR HINGE CUT-OUT PREPARATION

"K" SERIES WOOD DOOR MACHINING DETAILS  
USING 1-3/4" (45mm) HOLLOW OR SOLID CORE WOOD DOORS