

10 ga. .134 (3.4)  
HINGE REINFORCING

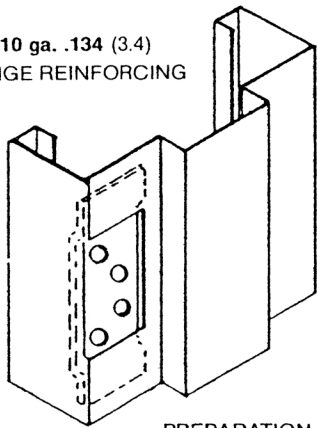

PREPARATION FOR  
4-1/2" x 4" (114 x 102)  
TEMPLATE HINGES  
REGULAR WEIGHT

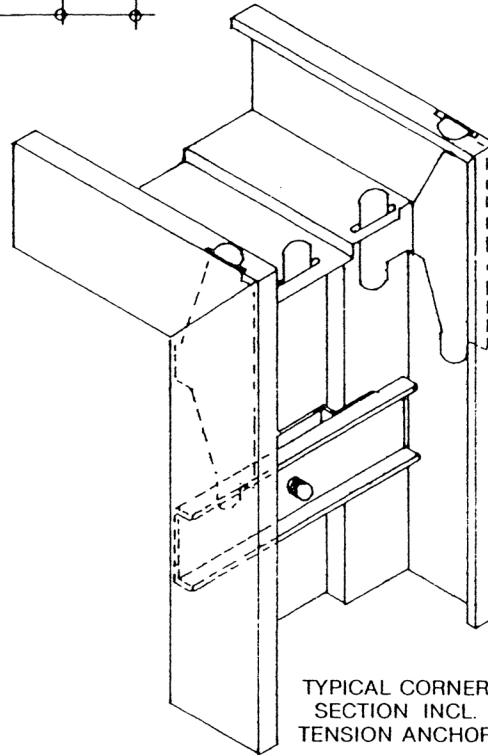

TYPICAL CORNER  
SECTION INCL.  
TENSION ANCHOR

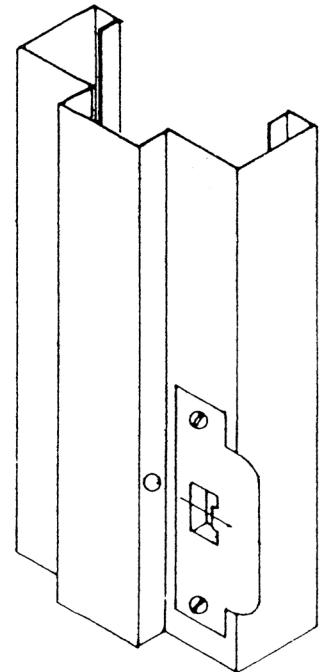

ANSI 1-1/4" x 4-7/8" (32 x 124)  
STRIKE ASSEMBLY

ORIGINAL DATE OF ISSUE — JULY 1978



REVISIONS

#

DATE

**NOTES**

General

1

Jan. '81

All dimensions given are subject to + or - 1/16" (± 2) tolerance.

See reverse side for specifications and for stock list.  
Dimensions shown in ( ) are in mm.