

* Optional 36 1/2" (927) strike location for 800 Series - Colonial Doors.

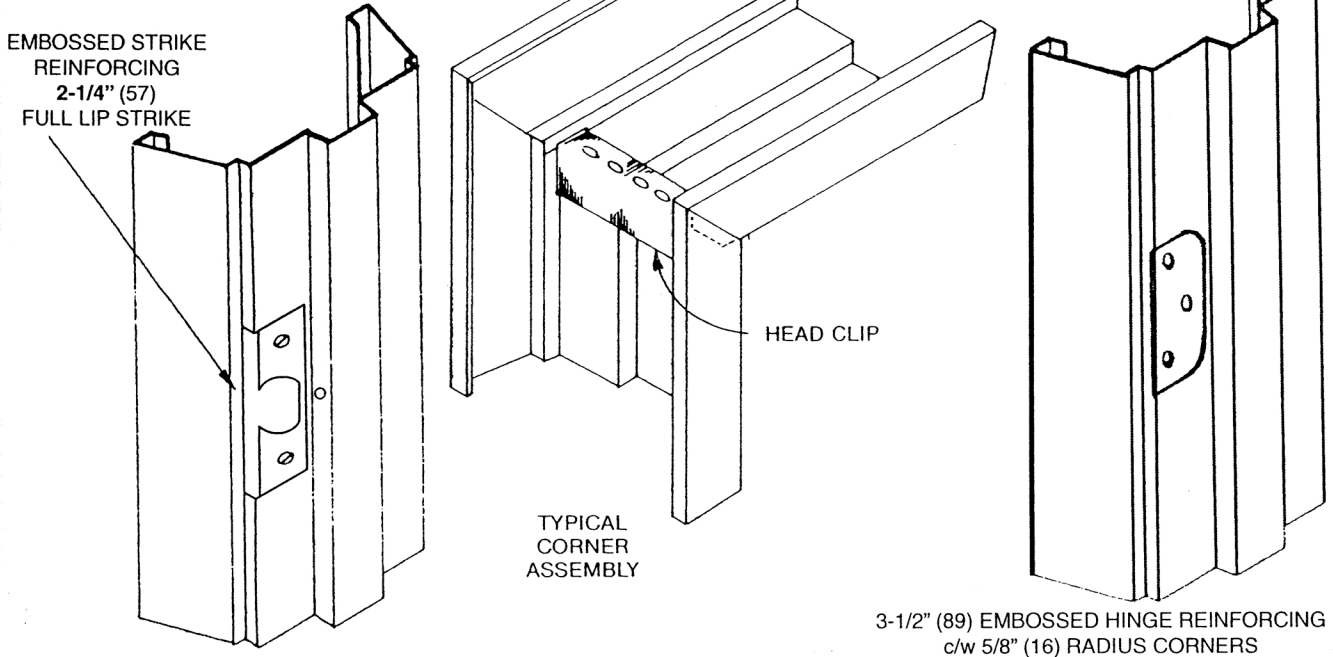

ORIGINAL DATE OF ISSUE — JULY 1978			LH SWING KEY RH
REVISIONS	#	DATE	NOTES All dimensions given are subject to + or - 1/16" (± 2) tolerance. See reverse side for specifications. Dimensions shown in () are in mm.
General	1	Jan. '81	
3-1/2" Hinge Preparation	2	Dec. '84	
Embossed Reinforcing	3	Mar/2010	