

* Standard 36-1/2" (927) strike location for 800 Series - Colonial Doors.

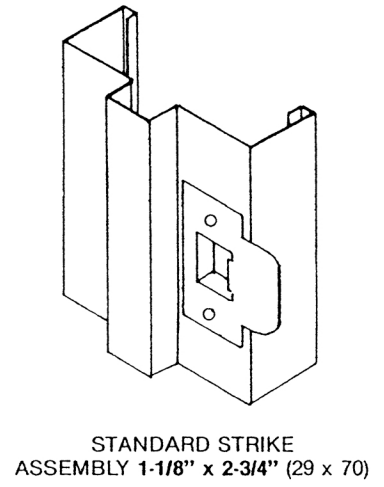
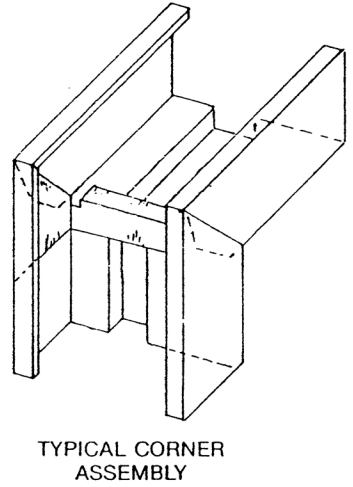
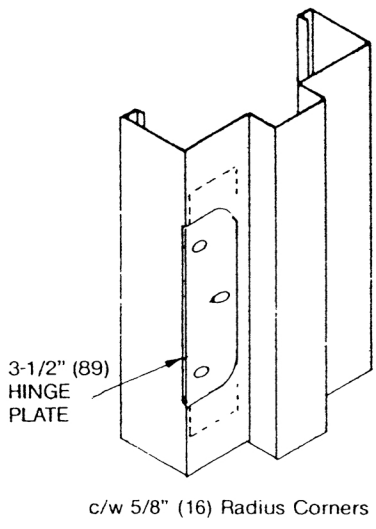

ORIGINAL DATE OF ISSUE — JULY 1978			LH SWING KEY RH
REVISIONS	#	DATE	NOTES All dimensions given are subject to + or - 1/16" (± 2) tolerance. See reverse side for specifications Dimensions shown in () are in mm.
General	1	Jan. '81	
Tension Anchor & Corner Assembly	2	Dec. '82	