

ELEV. #
FOR 1-3/4" SINGLE DOOR

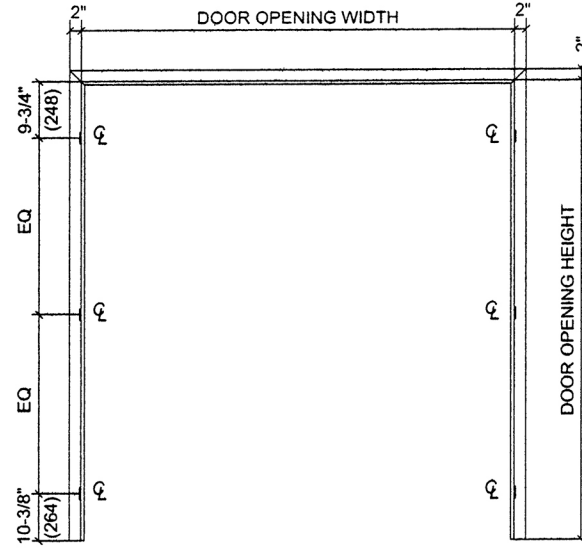

ELEV. #
FOR 1-3/4" DOUBLE DOORS

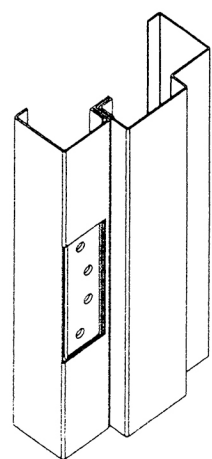
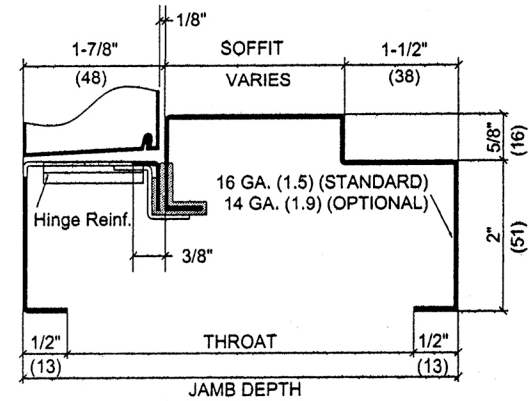

4-1/2" (114) UNIVERSAL HINGE PREPARATION
7Ga. (4.1) REINFORCEMENT WITH DUST BOX
FOR STANDARD OR HEAVY WEIGHT HINGES
D & T FOR #12-24 SCREW

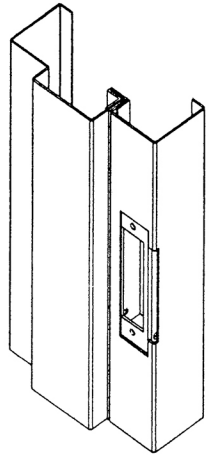

4-7/8" (124) STRIKE PREPARATION [ANSI A155.1]
14 Ga. (2.0) REINFORCEMENT WITH DUST BOX
D & T FOR #12-24 SCREW

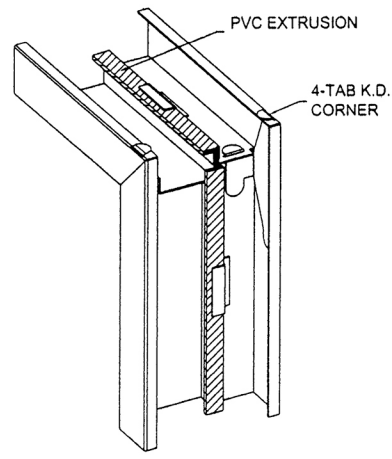

TYPICAL CORNER SECTION

	MODEL	JAMB DEPTH	AS 16	AS 14
			THROAT	THROAT
STD.	AS 475	4-3/4" (121)	3-3/4" (95)	3-3/4" (95)
	AS 575	5-3/4" (146)	4-3/4" (121)	4-3/4" (121)
	AS 675	6-3/4" (172)	5-3/4" (146)	5-3/4" (146)
	AS 875	8-3/4" (222)	7-3/4" (197)	7-3/4" (197)
ENG.	MINIMUM	4-1/2" (114)	3-1/2" (89)	3-1/2" (89)
	MAXIMUM	12-1/4" (311)	11-1/4" (286)	11-1/4" (286)

* ALL THERMAL BREAK FRAMES HAVE 1/2" SINGLE RETURN

NOTE: REFER TO TECHNICAL DATA MANUAL FOR FULL FIRE RATING INFORMATION

Drawing No.	"AS" SERIES THERMAL BREAK FRAMES	Date: 02/17/05	Drawn by: LX
PROJECT:	DAYBAR	SHEET: <input type="text"/> OF <input type="text"/>	