

# **PREHUNG DOOR SYSTEM INSTALLATION INSTRUCTIONS:** **SINGLE PREHUNGS, GARDEN/DOUBLE DOORS, VENTING SIDELITES** **WITH WOOD OR COMPOSITE FRAMES**

*Read all instructions before starting.*

Calgary Toll Free:  
1-866-664-7664

Saskatoon Toll Free:  
1-800-667-6977

Winnipeg Toll Free:  
1-855-706-0200

# Madero <sup>ca</sup>

## Doors & Hardware

### STEP 1: CHECK AND PREPARE OPENING

- ~ Clean and clear the work area.
- ~ The rough opening (RO) should be 1" wider and 1/2' taller than the outside measurement of the door frame.
- ~ Check RO for plumb, square and level.
- ~ Sub-floor is clean, dry and level. A solid, level sub-floor is essential for proper door unit installation. Scrape, sand and fill as required.

**Do not proceed with installation until the sub-floor is both solid and level.**

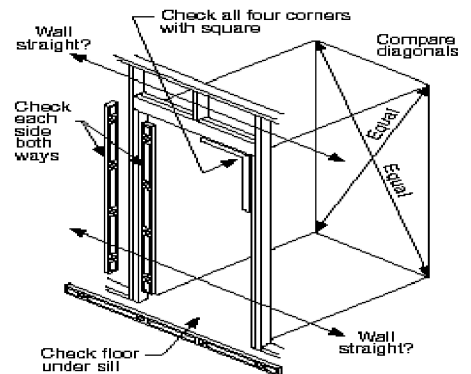

### STEP 2: CAULK SUB-FLOOR AND BOTTOM OF SILL

- ~ Remove all packaging materials. Door units are supplied with a "plug" or a double headed nail, which keeps the door closed in the frame during shipping. **Do not remove either at this time.**
- ~ Check the width and height of the door unit.
- ~ Apply 3 - 1/4" beads of caulking along the length of the sub-floor, starting from the inside edge.
- ~ Apply 3 - 1/4" beads of caulking along the bottom side of the sill, starting from the inside edge.

**Avoid callbacks due to leaks!**

**Caulking both the sub-floor and bottom of door sill is crucial.**

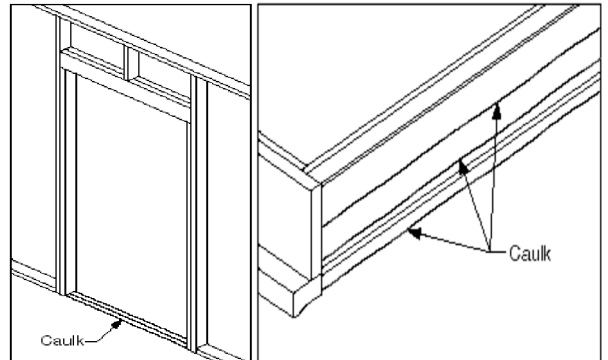

### STEP 3: PLACE THE DOOR UNIT IN ROUGH OPENING

- ~ 2 people are required for this step.
- ~ One person should be on the inside with shims ready and the other person on the outside.
- ~ Place the bottom of the door unit in the opening first and then tilt the unit up into the opening until the top of the unit is in the opening and the door unit is standing upright.

### STEP 4: SHIM AND FASTEN

#### **SINGLE DOORS**

- ~ Shim above fasteners behind each hinge and between jamb and the rough opening on the hinge side. The shims need to be placed below the vacant hole in the hinge.
- ~ Recheck hinge jamb using a 6' level to ensure it is plumb and straight.
- From the outside with the door closed check to ensure that the frame is not twisted.
- ~ From the strike side shim near the top and the bottom of the door. Adjust frame so margins between door and frame are even. From weatherstrip side of door check that weatherstrip margins and contact are equal around the door.
- ~ Recheck entire door unit for plumb, level, twisting and weatherstrip margins.
- ~ Open the door and drill 3 pilot holes through each vacant hinge hole.
- ~ Using the supplied 2-1/2" screws anchor the door through the pilot holes in the hinges into the jamb.
- ~ Close door and carefully shim between jamb and opening behind the latch.
- ~ Drill 2 pilot holes and place two 2-1/2 #8 screws through strike mounting holes to secure lock jamb center and provide security. On double strike units follow the same method using three 2-1/2 #8 screws through the vacant strike holes.
- ~ Adjust strike in or out for proper door operation and tighten screws.
- ~ It is recommended one additional screw is placed behind the weatherstrip at the top of the hinge jamb.
- ~ Check dust pad position to ensure no movement during transportation. Dust pads should be 1/2" from the top of the pvc portion of the sill to the bottom of the dust pad.

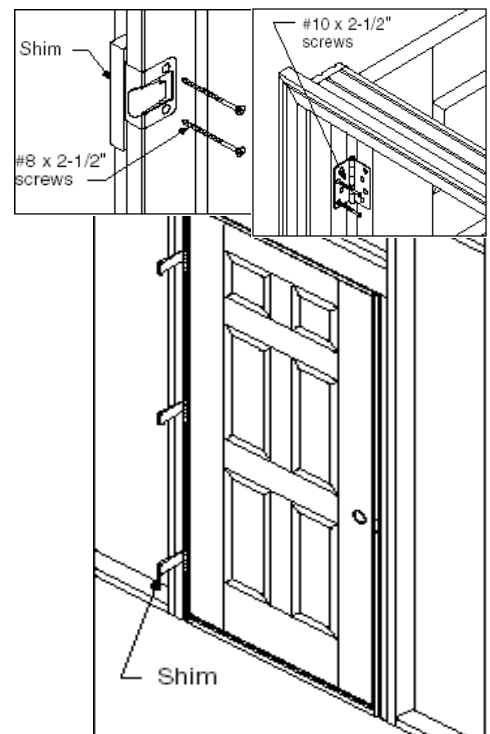

**DO NOT SCREW THROUGH SHIMS**

## STEP 5: DOORS WITH SIDELITES

Follow steps 1 - 4 on previous side, prior to installing units with doors and sidelites.

1. Shim the bottom corners of the door unit.
2. Shim the top of the door on the latch side. Adjust the shims until there is a consistent 1/8" gap between the top of the door slab and the header jamb.
3. Shim the top corner on both sides of the frame.
4. Follow the same instructions as in step #5 to check for twisting, weatherstrip margins and fastening through the hinges.
5. Open the door and sidelite and drill 3 pilot holes through each vacant hinge hole.

Using the supplied 2-1/2" screws, anchor the door through the pilot holes in the hinges into the jamb.

## STEP 6: GARDEN / DOUBLE DOORS

Follow steps 1 - 4 on previous side, prior to installing garden or double doors.

1. Shim the bottom corners of the door unit.
2. Shim the top of the door on the latch side. Adjust the shims until there is a consistent 1/8" gap between the top of the door slab and the header jamb.
3. Shim the top corner on both sides of the frame.
4. Follow the same instructions as in step #5 to check for twisting, weatherstrip margins and fastening through the hinges.
5. Open the doors and drill 3 pilot holes through each vacant hinge hole.

Using the supplied 2-1/2" screws, anchor the door through the pilot holes in the hinges into the jamb.

## STEP 7: WEATHERPROOF, FINISH AND MAINTAIN ENTRY DOOR SYSTEM

~ Caulk around entire unit on "weather" side: seal brickmould to siding or facing; seal front bottom edge of sill; seal all joints between jambs and moulding.

~ Seal joints between exterior hardware trim and door face to prevent air and water infiltration.

~ Provide and maintain a properly-installed cap flashing to protect top surfaces from water damage.

~ Paint or stain according to instructions. Do not paint gasketing or weather-stripping

~ Bare unprotected wood will weather and degrade and change color. All bare wood surfaces exposed to weather must be primed or stained and painted or finished within two weeks of exposure.

~ Maintain or replace sealants and finishes as soon as any deterioration is evident. For semi-gloss or glossy paints or clear coats, do this when surface becomes dull or rough. More severe exposures require more frequent maintenance. Swing-out doors must have all edges -- sides, top, and bottom -- finished.

Inspect and maintain these edges as regularly as all other surfaces.

### FINISHING INSTRUCTIONS

PAINT PREPARATION: Clean first with detergent and water, or use a TSP (trisodium-phosphate) solution. Do not wash doorlite frames and mouldings (see below). Rinse and let dry completely. Use only a high-quality 100% acrylic latex paint following manufacturer's directions for application. Use an exterior grade on outside. Paint edges and exposed ends of door.

IF PAINTING STEEL DOORLITE FRAMES AND MOULDINGS: Clean first by lightly wiping with a clean cloth. The material has a factory-applied surface preparation to improve finish adhesion. (Do not use stripping solvents on doorlite frames. This will damage or remove the surface preparation.) Mask off glass and finish with the same paint used for the door.

TO FINISH FIBERGLASS DOORLITE FRAMES AND PANEL INSERTS: Clean first. Use a dry rag or a clean cloth and mineral spirits, detergent and water or a TSP solution. Allow to dry before finishing. Work only when temperatures are between 50 degrees and 90 degrees F and with humidity less than 85%. Do not finish a door in direct sunlight.

TO PAINT: Prime first, and allow primer to dry before applying finish coat. Use primers and topcoats that are compatible. Either alkyd-based (oil) or water-based (latex) materials may be used. Use exterior-grade finishes on outside surfaces.

## TROUBLESHOOTING / CAUTIONS

- **Door is too tight or binds:** Check that the frame is square and plumb and not twisted. Ensure that the sill is not bowed and is level.
- **Daylight showing between frame and door:** Check weather strip margins and compression. Ensure dustpad is affixed to lower portion of the jamb leg. Make sure the door sweep is attached properly.
- **In order for the door unit to perform properly is it *CRITICAL* that the hinge and strike jambs are parallel to each other.**
- **Do not use the wall to square. Level and plumb the units.** Openings in walls are *rarely* square level and plumb.

**Units must be square, level and plumb to ensure proper operation and performance.**