

FALCON®

W Series and small rose

Medium duty, Grade 2 cylindrical
lever and knob locks

Overview

Falcon is dedicated to providing a solid product at a solid price no matter the application. When an affordable lock is needed for lower traffic doorways in government, retail, industrial or multi-family applications, the W Series lock fits perfectly. With two popular lever and knob styles as well as two popular rose diameters (big and small), Falcon can match most commercial door trim.

The Falcon W Series locks feature conventional cylinders and small format interchangeable cores that are compatible with SFIC products from other manufacturers. Our conventional cylinders are available in all Falcon conventional key sections, as well as Schlage® C keyway, which we now masterkey across the complete Falcon product line.



W Series

Medium duty, Grade 2 cylindrical lever and knob locks

The Falcon W Series is a solid product that offers versatility at a solid price.

- Reliable and proven Grade 2 construction
- Heavy duty springs for better lever return and to prevent sagging
- Non-handed for easy field assembly
- Abrasive lever coating option available
- Priced to fit your opening price point
- Schlage C masterkey available
- Manufactured to Allegion industry-leading quality standards

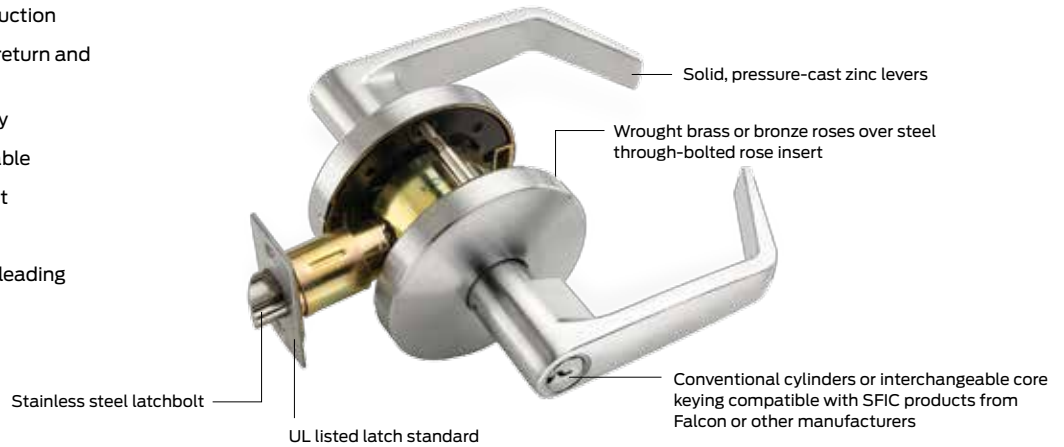

Lever and knob styles

Can be suited with a variety of Falcon locks such as mortise, tubular, Grade 1 cylindrical and interconnect.

Dane



Quantum



Hana



Elite



Rose diameters

The Falcon W comes in different rose diameters to meet your customer's needs. In addition to the 3 1/2" diameter, a smaller 2 9/16" diameter is available to meet narrow stile door requirements.

Large rose



Small rose



Available finishes



605/US3
Bright brass

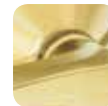

606/US4
Satin brass

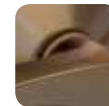

613/US10B
Oil rubbed bronze



625/US26
Bright chrome



626/US26D
Satin chrome

About Allegion

Allegion (NYSE: ALLE) creates peace of mind by pioneering safety and security. As a \$2 billion provider of security solutions for homes and businesses, Allegion employs more than 8,000 people and sells products in more than 120 countries across the world. Allegion comprises more than 25 global brands, including strategic brands CISA®, Interflex®, LCN®, Schlage® and Von Duprin®. For more, visit www.allegion.com.

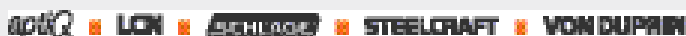

© 2014 Allegion
004188, Rev. 10/14
www.allegion.com/us